

CHP - Plant Gas + Steamturbine

Gansäuer

5. Aug 09

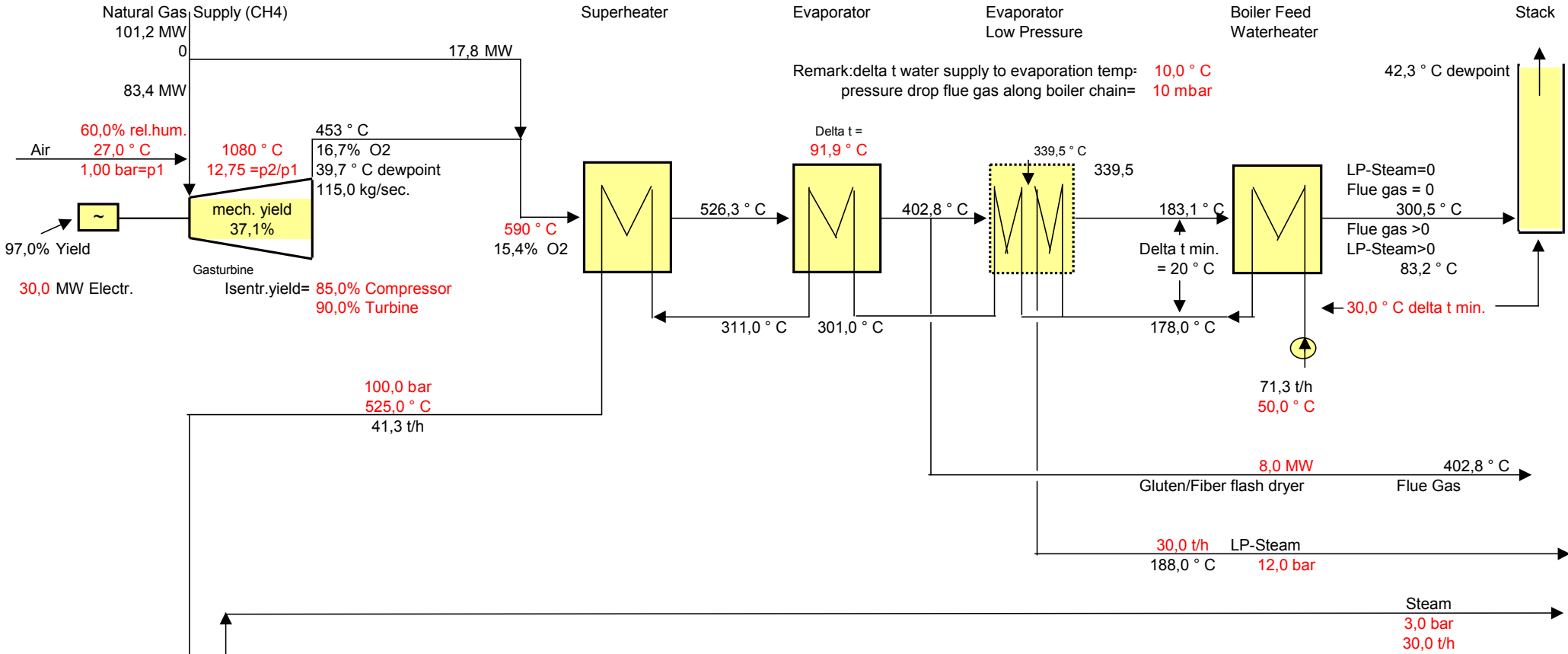

97,0% Yield
 9,1 MW Electr.
 Steamturb.
 Isentr.yield 83,0%
 Watercontent Vapor: = (Limit is 12 % !)

Condensor
 0,15 bar
 delta t = 8,0 °C
 718 m³/H
 6,7 MW
 Cooling Tower

| | |
|-------------------------------|------------------------|
| Powergeneration Gas: | 30,0 MW |
| Powergeneration Steam: | 9,1 MW |
| Total Powergeneration: | 39,1 MW (gross) |
| Gas supply Gasturbine: | 83,4 MW |
| Gas supply Topping: | 17,8 MW |
| Total Gas supply: | 101,2 MW |
| Overall electrical yield: | 38,6% (gross) |
| Overall efficeince: | 91,8% |